



HEIDENHAIN



Preliminary
Product Information

RCN 200 Series Absolute Angle Encoders

September 2005

	RCN 228 ¹⁾ RCN 226 ¹⁾		RCN 227 F ¹⁾ RCN 223 F ¹⁾	RCN 223 M
Absolute position values	EnDat 2.2 with incremental signals	EnDat 2.2 without incremental signals	Fanuc Serial interface	Mitsubishi high-speed serial interface
Ordering designation*	EnDat 02	EnDat 22	Fanuc 02	Mitsu 01
Positions per revolution	RCN 228: 268 435 456 (28 bits) RCN 226: 67 108 864 (26 bits)		RCN 227 F: 134 217 728 (27 bits) RCN 223 F: 8 388 608 (23 bits)	8 388 608 (23 bits)
Elec. permissible speed	1500 rpm			
Clock frequency	≤ 2 MHz	≤ 8 MHz	–	
Calculation time t_{cal}	5 μs		–	
Incremental signals	~ 1 V _{PP}	–		
Line count	16384	–		
Cutoff frequency –3 dB	≥ 180 kHz	–		
System accuracy*	RCN 228: ± 2.5" RCN 226: ± 5"		RCN 227 F: ± 2.5" RCN 223 F: ± 5"	± 5" or ± 2.5"
Power supply without load	3.6 V to 5.25 V at encoder/max. 350 mA			
Electrical connection	EnDat 02: Cable, 1 m, with M23 coupling (17-pin) EnDat 22: Cable, 1 m, with M12 coupling (8-pin)		Cable, 1 m, with M23 coupling (17-pin)	
Max. cable length²⁾	150 m		30 m	25 m
Mech. perm. speed	≤ 3000 rpm			
Starting torque	≤ 0.08 Nm at 20 °C			
Moment of inertia of rotor	73 · 10 ⁻⁶ kgm ²			
Natural frequency	≥ 1200 Hz			
Permissible axial motion of measured shaft	± 0.1 mm			
Vibration 55 to 2000 Hz Shock 6 ms	≤ 100 m/s ² (IEC 60068-2-6) ≤ 1000 m/s ² (IEC 60068-2-27)			
Operating temperature	For accuracy of ± 2.5": 0 to 50 °C For accuracy of ± 5": –10 to 70 °C			
Protection IEC 60529	IP 64			
Weight	Approx. 0.8 kg			

* Please indicate when ordering

¹⁾ Scheduled availability: 1st half of 2006

²⁾ With HEIDENHAIN cable

Mounting

The RCN housing is firmly connected to the stationary machine part with an integral mounting flange and a centering collar. Liquids can easily flow away through drainage channels on the flange and on the housing.

Shaft coupling with ring nut

The shaft is a hollow through shaft. For installation, the hollow through shaft of the angle encoder is placed over the machine shaft, and is fixed with a ring nut from the rear of the encoder. The ring nut can easily be tightened with the mounting tool.

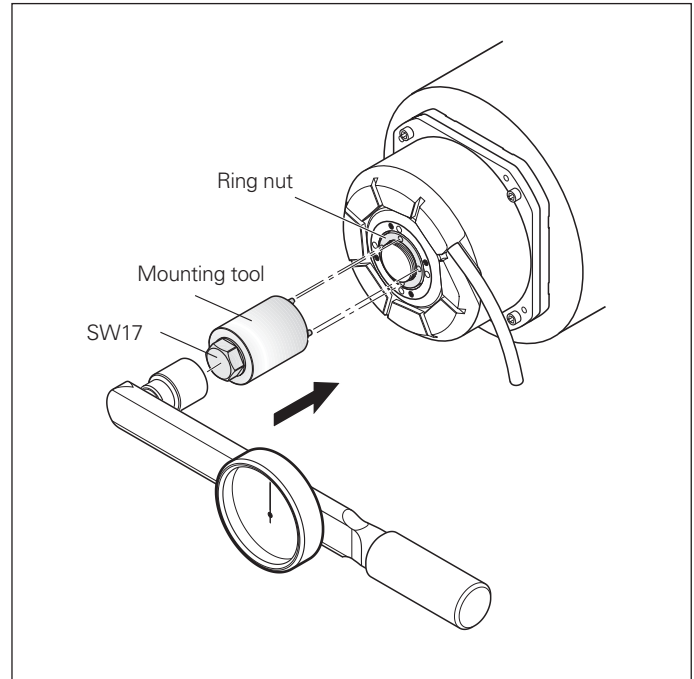

Front end shaft coupling

On some special applications it is helpful to mount the angle encoder onto the axis so that it is easily accessible when the rotor is removed.

This installation reduces mounting times, increases ease of servicing, and improves accuracy if the encoder is located nearer to the axis bearing and therefore closer to the measuring or machining plane. The hollow shaft is attached with the threaded holes on the face, using special mounting elements fitted to the individual design (not included in delivery).

To comply with radial and axial runout specifications, the internal bore ① and the shoulder surface ② are to be used as mounting surfaces for shaft coupling at the face of the encoder.

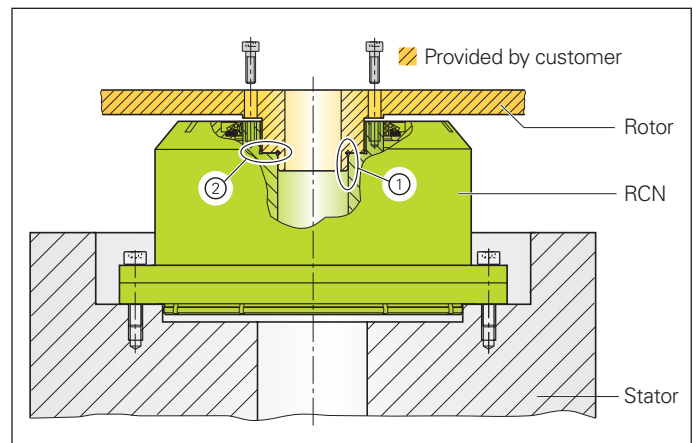

Accessories

Ring nuts

HEIDENHAIN offers special ring nuts for the RCN angle encoders with integral bearing and hollow through shaft with integrated coupling.

Choose the mating shaft thread such that the ring nut can be tightened easily with slight axial play. This guarantees that the load is evenly distributed on the shaft connection, and prevents distortion of the encoder's hollow shaft.



Ring nut for RCN 200

Hollow shaft \varnothing 20 mm: Id. Nr. 336669-03

Ring nut for
RCN 200 series

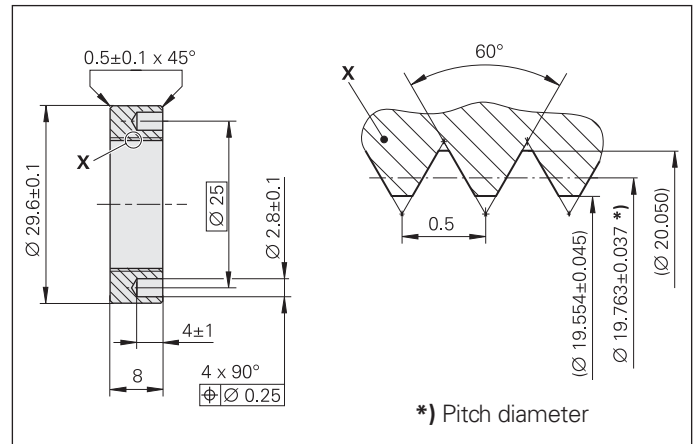

Mounting tool for HEIDENHAIN ring nuts

The mounting tool is used to tighten the ring nut. Its pins fit into holes in the ring nut. A torque wrench provides the necessary tightening torque.

Mounting tool for ring nuts with hollow shaft \varnothing 20 mm





Length 45 mm Id. Nr. 530334-03



Length 100 mm Id. Nr. 530334-30



Electrical Connection

EnDat 02 (EnDat 2.2 with Incremental Signals)

PUR connecting cable Ø 8 mm with M23 connecting element [[4 x 0.14 mm ²) + 4(2 x 0.14 mm ²) + (4 x 0.5 mm ²)]			
Complete with M23 connector (female), 17-pin and M23 coupling (male), 17-pin 	323897-xx	Complete with M23 connector (female), 17-pin and D-sub connector (male), 15-pin for IK 115 	324544-xx
With one connector M23 (female), 17-pin 	309778-xx	Complete with M23 connector (female), 17-pin and D-sub connector (female), 15-pin for HEIDENHAIN controls and for IK 220 	332115-xx
Cable without connectors 	266306-01		





17-pin coupling M23													
													
	Power supply					Incremental signals ¹⁾				Absolute position values			
	7	1	10	4	11	15	16	12	13	14	17	8	9
	U _P	Sensor U _P	0 V	Sensor 0 V	Inside shield	A+	A-	B+	B-	DATA	DATA	CLOCK	CLOCK
	Brown/ Green	Blue	White/ Green	White	/	Green/ Black	Yellow/ Black	Blue/ Black	Red/ Black	Gray	Pink	Violet	Yellow

Shield on housing; **U_P** = power supply voltage

Sensor: The sensor line is connected internally with the corresponding power line

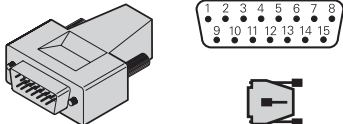
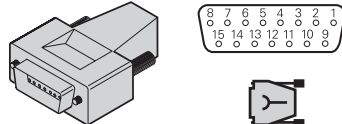
Vacant pins or wires must not be used!

¹⁾ Only with ordering designations EnDat 01 and EnDat 02

15-pin D-sub connector, male for IK 115/IK 215													
													
15-pin D-sub connector, female for HEIDENHAIN controls and IK 220													
													
	Power supply					Incremental signals ¹⁾				Absolute position values			
	4	12	2	10	6	1	9	3	11	5	13	8	15
	1	9	2	11	13	3	4	6	7	5	8	14	15
	U _P	Sensor U _P	0 V	Sensor 0 V	Inside shield	A+	A-	B+	B-	DATA	DATA	CLOCK	CLOCK
	Brown/ Green	Blue	White/ Green	White	/	Green/ Black	Yellow/ Black	Blue/ Black	Red/ Black	Gray	Pink	Violet	Yellow



Shield on housing; **U_P** = power supply voltage

Sensor: The sensor line is connected internally with the corresponding power line





Vacant pins or wires must not be used!

¹⁾ Only with ordering designations EnDat 01 and EnDat 02

EnDat 22 (EnDat 2.2 without Incremental Signals)

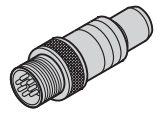
PUR connecting cable Ø 6 mm with M12 connecting element ¹⁾ [(4 x 0.14 mm ²) + (4 x 0.34 mm ²)]			
Complete with M12 connector (female), 8-pin and M12 coupling (male), 8-pin for purely serial data transmission 	368330-xx	Complete with M12 connector (female), 8-pin and D-sub connector (male), 15-pin for IK 215 	524599-xx

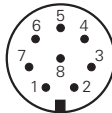
¹⁾ Consider voltage attenuation

8-pin coupling M12								
  								
	Power supply				Absolute position values			
	2	8	1	5	3	4	7	6
	U_P ¹⁾	U_P	0V ¹⁾	0V	DATA	DATA	CLOCK	CLOCK
	Blue	Brown/Green	White	White/Green	Gray	Pink	Violet	Yellow





Shield on housing; **U_P** = power supply voltage







¹⁾ For power lines configured in parallel

Vacant pins or wires must not be used!

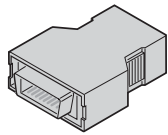
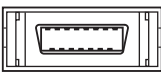

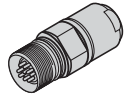
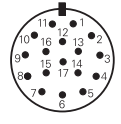



Fanuc O2 (Fanuc Serial Interface)

Mitsu O1 (Mitsubishi High Speed Serial Interface)

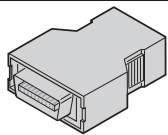
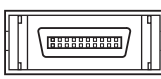
PUR adapter cable for Fanuc interface, Ø 8 mm		Connecting cable for Mitsubishi interface	
Complete with M23 connector (female) 17-pin, and Fanuc connector (female) 15-pin [(2 x 2 x 0.14 mm ²) + (4 x 1 mm ²)] 	534855-xx	Complete PUR Ø 6 mm with M23 connector (female), 17-pin and Mitsubishi connector (male), 20-pin [(2 x 2 x 0.14 mm ²) + (4 x 0.5 mm ²)] 	367958-xx
Cable only [(2 x 2 x 0.14 mm ²) + (4 x 1 mm ²)] 	354608-01	Cable only, PUR Ø 8 mm [(2 x 2 x 0.14 mm ²) + (4 x 1 mm ²)] 	354608-01

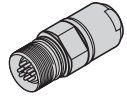
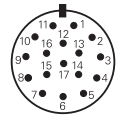
15-pin Fanuc connector					17-pin HEIDENHAIN coupling				
  					  				
Power supply					Absolute position values				
	9	18/20	12	14	16	1	2	5	6
	7	1	10	4	-	14	17	8	9
	U_P	Sensor U_P	0V	Sensor 0V	Shield	Serial Data	Serial Data	Request	Request
	Brown/ Green	Blue	White/ Green	White	-	Gray	Pink	Violet	Yellow

Shield on housing for 17-pin HEIDENHAIN coupling; **U_P** = power supply
Sensor: The sensor line is connected internally with the corresponding power line
 Vacant pins or wires must not be used.

20-pin Mitsubishi connector					17-pin HEIDENHAIN coupling			
  					  			
Power supply					Absolute position values			
	20	19	1	11	6	16	7	17
	7	1	10	4	14	17	8	9
	U_P	Sensor U_P	0V	Sensor 0V	Serial Data	Serial Data	Request Frame	Request Frame
	Brown/Green	Blue	White/Green	White	Gray	Pink	Violet	Yellow

Shield on housing; **U_P** = power supply voltage
Sensor: The sensor line is connected internally with the corresponding power line
 Vacant pins or wires must not be used

HEIDENHAIN

DR. JOHANNES HEIDENHAIN GmbH
 Dr.-Johannes-Heidenhain-Straße 5
83301 Traunreut, Germany
 ☎ +49 (8669) 31-0
 📠 +49 (8669) 5061
 e-mail: info@heidenhain.de

www.heidenhain.de

For more information
 Brochure: *Angle Encoders*